



Heatex

WATER HEATER



The Smart Choice



HEATEX WATER HEATER

VERTICAL WALL MOUNT

30 - 75 Liters

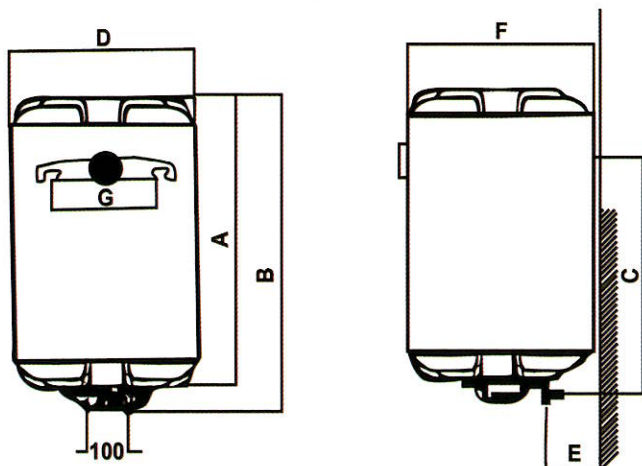

HT8-V



HT45-V



HT16-V



HT20-V

Model Number	Capacity (Liters)	Dimensions (mm)							Capacity (Liters)	Power (Watt)	Voltage (Volt)	Heating Time (Hours)	Maximum Working Temp (C°)	Maximum Working Pressure (PSI)
		A	B	C	D	E	F	G						
HT8-V	30	475	495	344	390	150	425	270	30	1200	220-240	1.32	70	116
HT45-V	45	575	595	395	390	150	425	270	45	1200	220-240	1.97	70	116
HT16-V	60	765	785	900	390	150	425	270	60	1200	220-240	3.1	70	116
HT20-V	75	880	900	720	390	150	425	270	75	1500	220-240	2.62	70	116

HEATEX WATER HEATER

HORIZONTAL WALL MOUNT

50-75 Liters

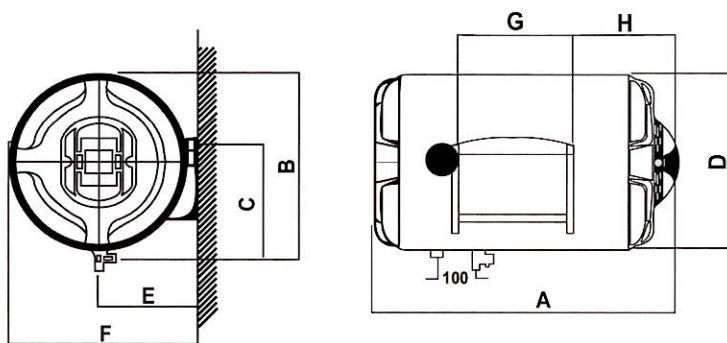

HT12-H



HT20-H

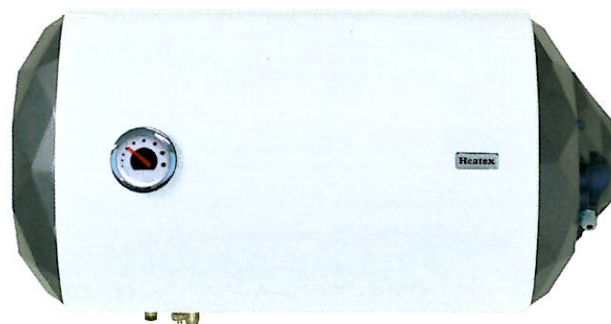

HT16-H

Model Number	Capacity (Liters)	Dimensions (mm)							
		A	B	C	D	E	F	G	H
HT12-H	50	595	410	340	390	215	425	270	220
HT16-H	60	765	410	385	390	215	425	290	270
HT20-H	75	880	410	385	390	215	425	290	270

Capacity (Liters)	Power (Watt)	Voltage (Volt)	Heating Time (Hours)	Maximum Working Temp (C°)	Maximum Working Pressure (PSI)
50	1200	220-240	2.2	70	116
60	1200	220-240	3.1	70	116
75	1500	220-240	2.62	70	116

HEATEX WATER HEATER

SPARES & ACCESSORIES



Temperature Gauge



Safety Valve



Magnesium Anode
(Optional)

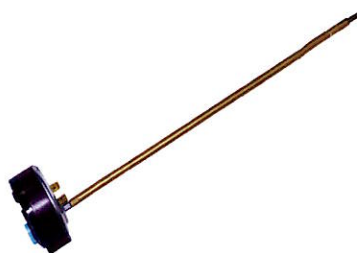

Thermostat



Heating Element



PACKAGING & SHIPPING INFORMATION

CAPACITY (LITERS)	UNIT VOLUME (CU/M)	GROSS WEIGHT (KG)	NET WEIGHT (KG)	UNITS IN 40 FEET CONTAINER	UNITS IN 50 FEET TRAILER
30	0.0930	10.60	9.50	700	850
45	0.1110	12.5	10.5	560	680
50	0.1237	14	12.50	490	612
60	0.1453	16	14	420	510
75	0.1661	19	17	364	408



OMAN



IRAQ



IRAN



SAUDI ARABIA



BAHRAIN



SYRIA



KUWAIT



QATAR



ALGERIA



MOROCCO



AFGHANISTAN



MALTA



AZERBAIJAN



NIGERIA



SUDAN



GHANA

HEATEX WATER HEATERS

Tel: +971 6 743 4389 (Ajman, U.A.E.)

E-mail: zenithok@eim.ae, www.zenithuae.net